

3E-34N SERIES - 1/15 HP

APPLICATIONS

Dual purpose oil-filled pump that may be used totally submersed or in-line (fed with pipe or hose). For commercial, industrial and home applications including statuary fountains, water displays, air conditioners, machine tool coolants, and many other applications where liquid must be transferred or recirculated.

FEATURES

- For submersed or in-line use
- Epoxy-coated die-cast aluminum housing
- Oil-filled motor
- 20.3-foot maximum lift
- Snap-on pre-filter screen
- 1/2-inch MNPT discharge
- Thermal overload protection



3E-34N



SERIES SPECIFICATIONS

Item No.	Model	Discharge	Intake	HP	Volts	Hz	Amps	Watts	Gallons per hour (Liter per hour) @ Height				Shut-Off	PSI	Cord	Weight lbs (Kg)
									1'	3'	5'	10'				
503603	3E-34N	1/2" MNPT	3/4" MNPT	1/15	115	60	3.2	200	670 (2536)	650 (2461)	575 (2177)	460 (1741)	20.3' (6.2 m)	8.8	10' (3 m)	7.5 (3.40 Kg)

SMALL SUBMERSIBLE PUMPS

3E-34N SERIES - 1/15 HP

ENGINEERING DATA

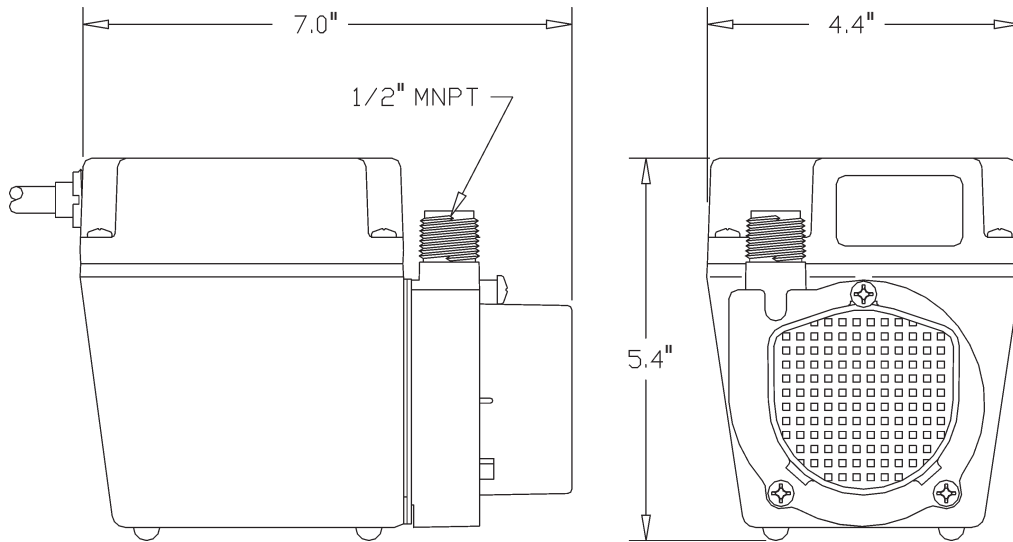

PERFORMANCE DATA

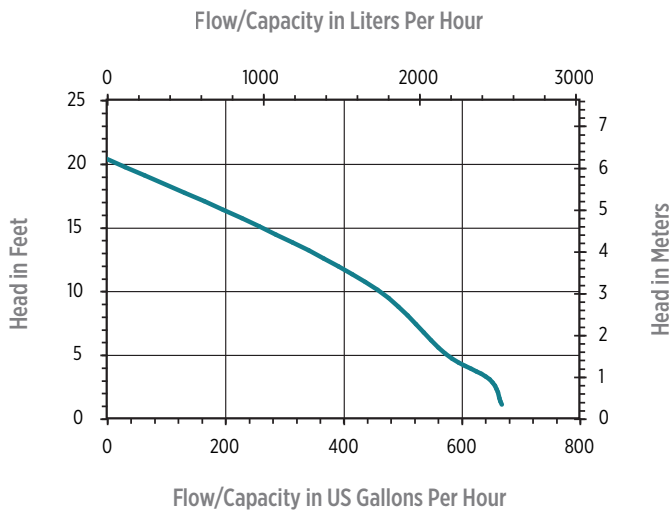

REPLACEMENT PARTS

Volute	103337
Impeller	103437
Screen	102376
Gasket	103601

